

Our services  
go far beyond  
expectations.

**BUCKET ELEVATORS AND ACCESSORIES**

# Heavy Duty Bucket Elevators

Grain Belt Bucket Elevators have been designed and engineered for handling your bulk material.

## GRAIN BELT STANDARD FEATURES

- High speed one-piece elevator buckets (metal or plastic).
- Quality ball bearings used throughout.
- 12 ga. dust and weatherproofed head and vent cap.
- 12 ga. bolt together boot with cleanout slides and one pocket.
- 14 ga. welded steel leg sections (Two-piece construction).
- Jig built for easy field erection.
- Solid steel head and boot pulleys.
- Head pulley crowned, lagged and keyed.
- Adjustable throat plate.
- P.V.C. belt pre-punched.
- Full access inspection section.

## GRAIN BELT OPTIONAL FEATURES

- Work platforms
- Distributor platforms
- Ladder
- Safety cage
- Rest platforms
- Explosion vents
- Wing type boot pulley
- Available in mild steel, stainless steel, or galvanized

ELEVATOR LEG HORSE POWER AND SHAFT SIZE								
BPH	500	1000	1500	2000	2500	3000	3500	Headshaft Diameter
Discharge Height/Ft.	9 x 5 14" CC	9 x 5 12" CC	9 x 5 8" CC	9 x 5 6" CC	9 x 6 7" CC	9 x 6 7" CC	9 x 6 LP 5" CC	
RPM	55	90	90	90	95	110	90	
20	1	1	1½	2	2	3	3	1 <sup>15</sup> / <sub>16</sub> "
25	1	1	1½	2	3	3	5	
30	1	1½	2	3	3	5	5	
35	1	1½	2	3	5	5	5	
40	1	2	3	5	5	5	7½	
45	1	2	3	5	5	7½	7½	
50	1½	3	5	5	7½	7½	7½	
55	1½	3	5	5	7½	7½	7½	
60	1½	3	5	5	7½	7½	10	
65	1½	3	5	5	7½	7½	10	
70	1½	3	5	7½	7½	10	10	
75	1½	3	5	7½	7½	10	10	
80	2	5	5	7½	10	10	15	
85	2	5	5	7½	10	10	15	
90	2	5	7½	7½	10	15	15	
95	2	5	7½	7½	10	15	15	
100	2	5	7½	10	10	15	15	
105	2	5	7½	10	10	15	15	
110	3	5	7½	10	15	15	15	
115	3	5	7½	10	15	15		
120	3	5	7½	10	15	15		

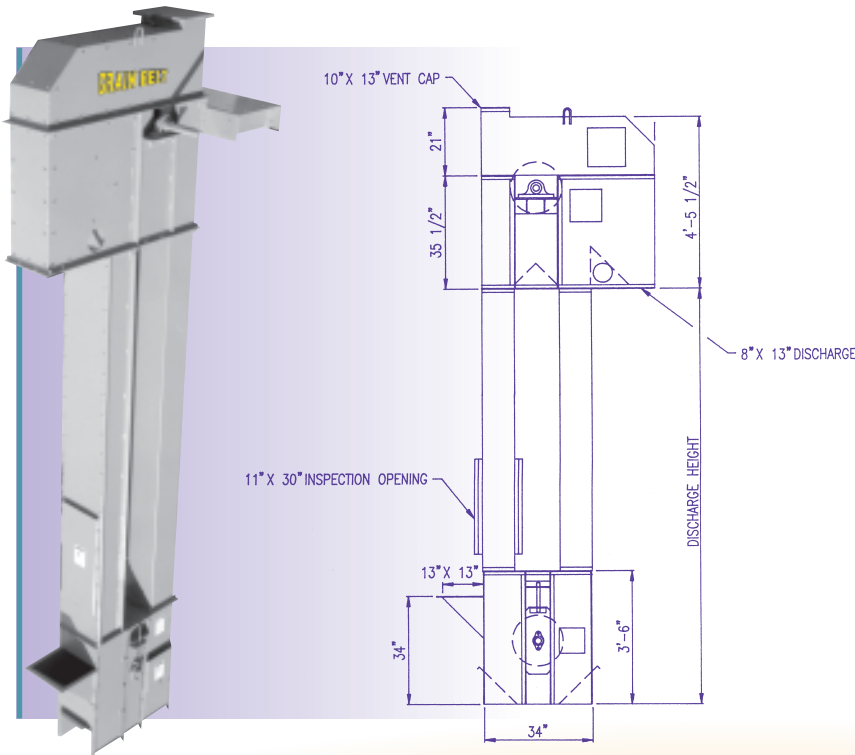

## 500 TO 3500 BPH STOCK HEAVY-DUTY BUCKET ELEVATOR SPECIFICATIONS

### HEAD

12 ga., two piece construction, ¼" expanded metal backed urethane lined front crown and discharge, 16" x 11" keyed and lagged pulley, 12" sq. & 10" sq. inspection openings, dust seals on head shaft, adjustable throat plate.

### BOOT

12 ga., bolted construction, 9" travel take-ups, one loading pocket, 1 15/16" shaft, 16" x 11" pulley, 8" sq. inspection opening, removable clean out slides.

### TRUNKING

Standard trunking available in 20', 10' and 5' lengths. 14 ga., two piece design, 10" x 13" cross section, 1 ¼" angle flanges, inspection section with 10' bolt on side and two 11" x 30" inspection doors.

### GENERAL

10" wide PVC belting, 9" x 5" and 9" x 6" Grain Belt steel or plastic CC style elevator cups.

We will custom manufacture any bucket elevator to your specifications.

# 8000 to 15000 Stock Industrial Duty Bucket Elevators

## GRAIN BELT STANDARD FEATURES

- High-speed one-piece elevator buckets (metal or plastic).
- Solid steel head and boot pulleys.
- Head pulley crowned, lagged and keyed.
- 10 ga. dust and weatherproofed head and vent cap.
- 7 ga. bolted steel boot with cleanout slides and two pockets.
- 12 ga. welded steel leg sections (Two piece construction).
- Full access inspection section.
- Jig built for easy field erection.
- Two boot pockets; feeds buckets uniformly up or down side.
- P.V.C. belt pre-punched.
- Dust seals on the boot shaft.
- Long lasting, high quality bearings.
- Adjustable throat plate.

## GRAIN BELT OPTIONAL FEATURES

- Work platforms
- Distributor platforms
- Ladder
- Safety cage
- Rest platforms
- Explosion vents
- Wing type boot pulley
- Available in mild steel, stainless steel, or galvanized

## 8000 TO 15000 BPH STOCK INDUSTRIAL DUTY BUCKET ELEVATOR SPECIFICATIONS

### HEAD

10 ga., three piece construction, 1/4" expanded metal backed urethane lined front crown and discharge, 42" x 19" keyed and lagged pulley, 12" sq. inspection opening, dust seals on head shaft, adjustable throat plate.

### BOOT

7 ga., bolted construction, 12" travel take-ups, two loading pockets, 3 7/16" shaft with Pillow Block Bearings, 42" x 19" pulley, 8" sq. inspection opening, dust seals on the boot shaft, removable clean out slides.

### TRUNKING

Standard trunking available in 20', 10' and 5' lengths. 12 ga., two piece design, 15" x 22" cross section, inspection section with 10" bolt on side and two 22" x 30" inspection doors.

### GENERAL

18" wide PVC belting, 16" x 7" or 16" x 8" Grain Belt plastic or steel CC style elevator cups.

MODEL 42A ELEVATOR LEG HORSE POWER AND SHAFT SIZE									
BPH Discharge Height/Ft.	8000 16 x 7 10.75 CC	9000 16 x 7 9.125 CC	10000 16 x 7 8.625 CC	11000 16 x 8 9.125 CC	12000 BJ 16x8 10.625 CC	13000 BJ 16x8 9.875 CC	14000 BJ 16x8 9.125 CC	15000 BJ 16x8 8.5 CC	Headshaft Diameter
RPM	63	63	63	63	63	63	63	63	
25	10	10	10	15	15	15	15	15	2 15/16"
30	10	15	15	15	15	15	20	20	3 7/16"
35	15	15	15	15	20	20	20	20	
40	15	15	20	20	20	20	25	25	
45	15	20	20	20	25	25	25	30	
50	20	20	20	25	25	25	30	30	
55	20	20	25	25	30	30	30	40	3 15/16"
60	20	25	25	30	30	30	40	40	
65	20	25	25	30	30	40	40	40	
70	25	25	30	30	40	40	40	40	
75	25	30	30	40	40	40	40	50	4 7/16"
80	25	30	40	40	40	40	50	50	
85	30	30	40	40	40	50	50	50	
90	30	40	40	40	50	50	50	60	
95	30	40	40	40	50	50	60	60	
100	40	40	40	50	50	50	60	60	
105	40	40	40	50	50	60	60	60	
110	40	40	50	50	60	60	60	75	4 15/16"
115	40	40	50	50	60	60	75	75	
120	40	50	50	60	60	60	75	75	
125	40	50	50	60	60	75	75	75	
130	40	50	50	60	60	75	75	75	
135	50	50	60	60	75	75	75	100	5 7/16"
140	50	50	60	60	75	75	75	100	
145	50	50	60	75	75	75	100	100	
150	50	60	60	75	75	75	100	100	
155	50	60	60	75	75	100	100	100	
160	50	60	75	75	75	100	100	100	
165	60	60	75	75	100	100	100	100	
170	60	60	75	75	100	100	100	100	
175	60	60	75	75	100	100	100	100	
180	60	75	75	100	100	100	100	125	
185	60	75	75	100	100	100	100	125	
190	60	75	75	100	100	100	125	125	
195	60	75	75	100	100	100	125	125	
200	75	75	100	100	100	100	125	125	
205	75	75	100	100	100	125	125	125	
210	75	75	100	100	100	125	125	125	
215	75	75	100	100	100	125	125	125	
220	75	100	100	100	125	125	125	-	

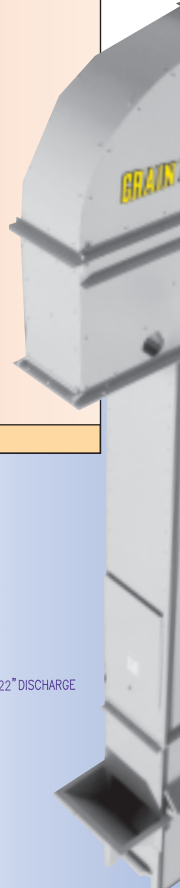
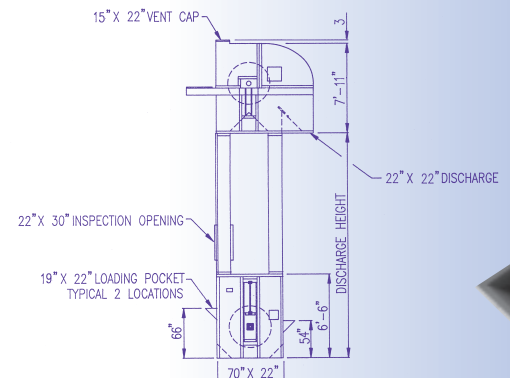

# 14000 to 20000 Industrial Duty Bucket Elevators

## GRAIN BELT STANDARD FEATURES

- High-speed one-piece elevator buckets (metal or plastic).
- Solid steel head and boot pulleys.
- Head pulley crowned, lagged and keyed.
- 10 ga. dust and weatherproofed head and vent cap.
- 7 ga. bolted steel boot with cleanout slides and two pockets.
- 12 ga. welded steel leg sections (Two piece construction).
- Full access inspection section.
- Jig built for easy field erection.
- Two boot pockets; feeds buckets uniformly up or down side.
- P.V.C. belt pre-punched.
- Dust seals on the boot shaft.
- Long lasting, high quality bearings.
- Adjustable throat plate.

## GRAIN BELT OPTIONAL FEATURES

- Work platforms
- Distributor platforms
- Ladder
- Safety cage
- Rest platforms
- Explosion vents
- Wing type boot pulley
- Available in mild steel, stainless steel, or galvanized

MODEL 42B ELEVATOR LEG HORSE POWER AND SHAFT SIZE								
BPH Discharge Height/Ft.	14000 BJ 20 x 8 11.75 CC	15000 BJ 20 x 8 10.75 CC	16000 BJ 20 x 8 10.25 CC	17000 BJ 20 x 8 9.5 CC	18000 BJ 20 x 8 9 CC	19000 BJ 20 x 8 8.5 CC	20000 BJ 20 x 8 8.5 CC	Headshaft Diameter
RPM	63	63	63	63	63	63	66	
25	15	15	20	20	20	20	20	3 7/16"
30	20	20	20	20	25	25	25	
35	20	20	25	25	25	30	30	
40	25	25	25	30	30	30	40	3 15/16"
45	25	30	30	30	40	40	40	
50	30	30	40	40	40	40	40	
55	30	40	40	40	40	40	50	4 7/16"
60	40	40	40	40	50	50	50	
65	40	40	40	50	50	50	50	
70	40	40	50	50	50	60	60	
75	40	50	50	50	60	60	60	
80	50	50	50	60	60	60	75	4 15/16"
85	50	50	60	60	60	75	75	
90	50	60	60	60	75	75	75	
95	60	60	60	75	75	75	75	
100	60	60	75	75	75	75	100	5 7/16"
105	60	60	75	75	75	100	100	
110	60	75	75	75	100	100	100	
115	75	75	75	75	100	100	100	
120	75	75	75	100	100	100	100	
125	75	75	100	100	100	100	100	
130	75	75	100	100	100	100	100	
135	75	100	100	100	100	100	125	
140	75	100	100	100	100	125	125	
145	100	100	100	100	100	125	125	
150	100	100	100	100	125	125	125	
155	100	100	100	100	125	125	125	
160	100	100	100	125	125	125	125	
165	100	100	125	125	125	125	150	5 15/16"
170	100	100	125	125	125	125	150	
175	100	100	125	125	125	150	150	
180	100	125	125	125	125	150	150	
185	100	125	125	125	150	150	150	
190	125	125	125	125	150	150	150	
195	125	125	125	150	150	150	150	
200	125	125	125	150	150	150	200	6 1/2"
205	125	125	125	150	150	150	200	
210	125	125	150	150	150	200	200	
215	125	125	150	150	150	200	200	
220	125	150	150	150	200	200	200	

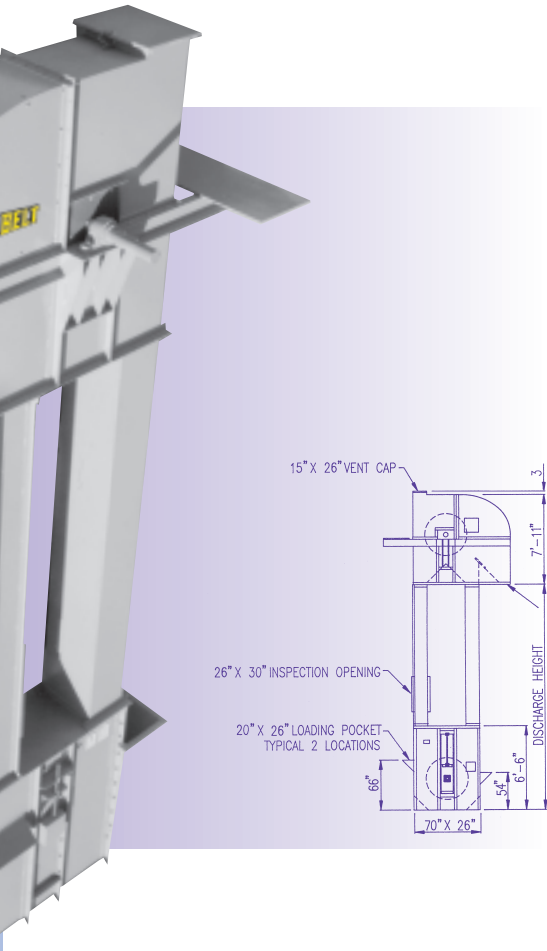

## 14000 TO 20000 BPH INDUSTRIAL DUTY BUCKET ELEVATOR SPECIFICATIONS

### HEAD

10 ga., three piece construction, 1/4" expanded metal backed urethane lined front crown and discharge, 42" x 23" keyed and lagged pulley, 12" sq. inspection opening, dust seals on head shaft, adjustable throat plate.

### BOOT

7 ga., bolted construction, 12" travel take-ups, two loading pockets, 3 15/16" shaft with Pillow Block Bearings, 42" x 23" pulley, 8" sq. inspection opening, dust seals on the boot shaft, removable clean out slides.

### TRUNKING

Standard trunking available in 20', 10' and 5' lengths. 12 ga., two piece design, 15" x 26" cross section, inspection section with 10' bolt on side and two 26" x 30" inspection doors.

### GENERAL

22" wide PVC belting, 20" x 8" plastic or steel CC style elevator cups.

# Industrial Duty Bucket Elevators

We offer quality and dependability, backed by over 47 years of experience in the grain handling industry.

## GRAIN BELT STANDARD FEATURES

- High-speed one-piece elevator buckets (metal or plastic).
- Solid steel head and boot pulleys.
- Head pulley crowned, lagged and keyed.
- 12 ga. dust and weatherproofed head and vent cap.
- 10 ga. steel boot with cleanout slides and two pockets.
- 14 ga. welded steel leg sections (Two piece construction).
- Full access inspection section.
- Jig built for easy field erection.
- Two boot pockets; feeds buckets uniformly up or down side.
- P.V.C. belt pre-punched.
- Boot shaft bearings covered.
- Long lasting, high quality bearings.
- Adjustable throat plate.

## GRAIN BELT OPTIONAL FEATURES

- Work platforms
- Distributor platforms
- Ladder
- Safety cage
- Rest platforms
- Explosion vents
- Wing type boot pulley
- Available in mild steel, stainless steel, or galvanized

## 4000 TO 8000 BPH STOCK INDUSTRIAL BUCKET ELEVATOR SPECIFICATIONS

### HEAD

12 ga., three piece construction, 1/4" expanded metal backed urethane lined front crown and discharge, 30" x 15" keyed and lagged pulley, 12" sq. inspection opening, dust seals on head shaft, adjustable throat plate.

### BOOT

10 ga., bolted construction, 12" travel take-ups, two loading pockets, 2 7/16" shaft, 30" x 15" pulley, 8" sq. inspection opening, dust covers over bearings, removable clean out slides.

### TRUNKING

14 ga., two piece design, 13" x 18" cross section, inspection section with 10' bolt on side and two 18" x 30" inspection doors.

### GENERAL

14" wide PVC belting, 13" x 6" or 13" x 7" Grain Belt plastic or steel CC style elevator cups.

ELEVATOR LEG HORSE POWER AND SHAFT SIZE										
BPH	4000	4500	5000	5500	6000	6500	7000	7500	8000	
Discharge Height/Ft.	13 x 6 11" CC	13 x 6 9 3/4" CC	13 x 6 8 3/4" CC	13 x 6 8" CC	13 x 7 9 1/2" CC	13 x 7 8 1/2" CC	13 x 7 8" CC	13 x 7 7 1/2" CC	13 x 7 7" CC	Headshaft Diameter
RPM	73	73	73	73	73	73	73	73	73	
25	5	5	5	7 1/2	7 1/2	7 1/2	7 1/2	7 1/2	10	2 7/16"
30	5	7 1/2	7 1/2	7 1/2	7 1/2	7 1/2	10	10	10	
35	7 1/2	7 1/2	7 1/2	7 1/2	10	10	10	10	15	2 15/16"
40	7 1/2	7 1/2	10	10	10	10	15	15	15	
45	7 1/2	10	10	10	15	15	15	15	15	
50	10	10	10	15	15	15	15	15	20	
55	10	10	15	15	15	15	15	20	20	
60	10	15	15	15	15	15	20	20	20	
65	10	15	15	15	15	20	20	20	20	3 7/16"
70	15	15	15	15	20	20	20	20	25	
75	15	15	15	20	20	20	20	25	25	
80	15	15	20	20	20	20	25	25	25	
85	15	15	20	20	20	25	25	25	30	
90	15	20	20	20	25	25	25	30	30	
95	15	20	20	20	25	25	30	30	30	3 15/16"
100	20	20	20	25	25	25	30	30	30	
105	20	20	20	25	25	30	30	30	40	
110	20	20	25	25	25	30	30	40	40	
115	20	20	25	25	30	30	40	40	40	
120	20	25	25	25	30	30	40	40	40	
125	20	25	25	30	30	40	40	40	40	-
130	20	25	25	30	30	40	40	40	40	
135	25	25	30	30	40	40	40	40	50	
140	25	25	30	30	40	40	40	40	50	
145	25	25	30	40	40	40	40	50	50	
150	25	30	30	40	40	40	40	50	50	
155	25	30	30	40	40	40	50	50	50	-
160	25	30	40	40	40	40	50	50	50	
165	25	30	40	40	40	50	50	50	50	
170	30	30	40	40	40	50	50	50	-	-
175	30	30	40	40	40	50	50	50	-	
180	30	40	40	40	50	50	50	-	-	

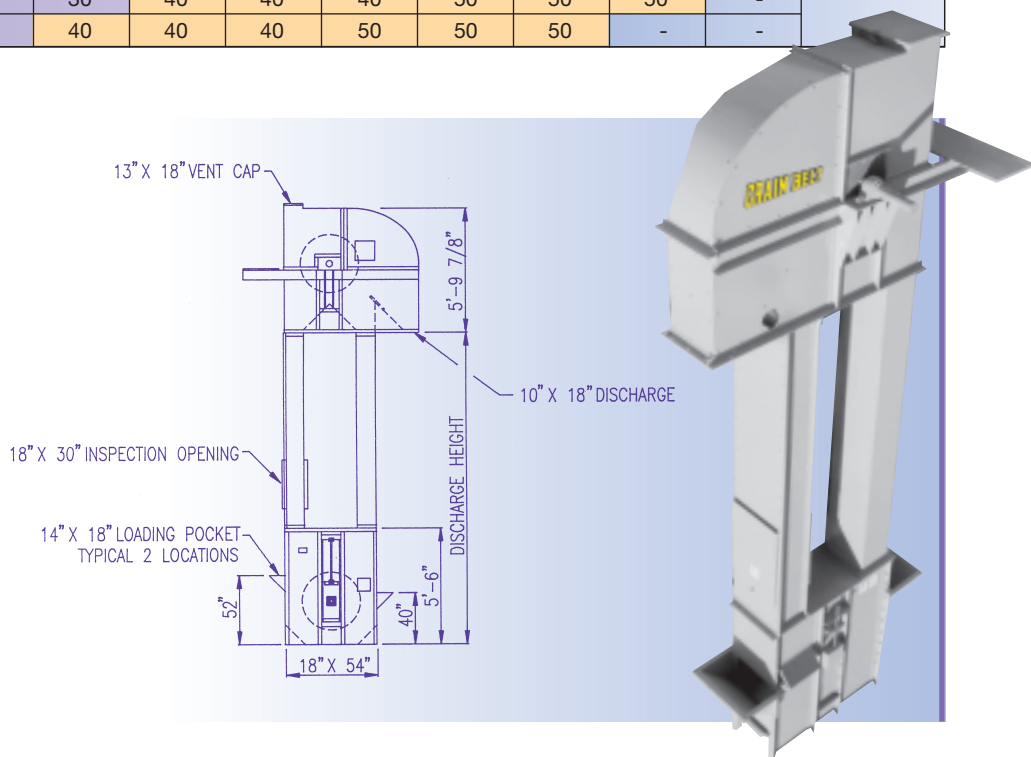

# Grain Belt Catwalk

## SPECIFICATIONS

- Heavy reinforced welded steel construction.
- 3" channel frame.
- Deck made of 3.14# expanded metal grate.
- 1½" square tubing handrail and posts 42" high with kick plate.
- 3" x 2" x 3/16" angle iron cross members to support catwalk and make snug fit to elevator.
- Opening in decking provided for easy access from ladder.

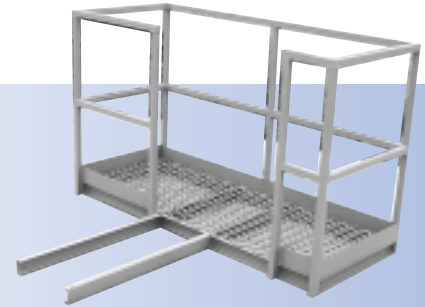

# All Steel Ladder and Cage

## Cage

- 1/8" x 1½" stringers.
- 3/16" x 2" hoops.
- 5' or 10' sections.
- 28" inside diameter allows plenty of room to climb.
- Flared sections available in 5' lengths.

## Ladder

- 1/4" x 2" flat side rails.
- 3/4" round rungs on 12" centers.
- Complete with splice bars, mounting brackets, and bolts for erection.
- Wall mounting brackets supplied for installation for each 10 ft. of ladder.

## Rest Platforms

- Heavy reinforced welded steel construction.
- Deck made of 3.14# expanded metal grate.
- 1½" square tubing handrail and posts 42" high with kick plate.
- Field assembly right or left hand.



Meets all OSHA requirements.

Serving the grain handling and feed mill industry for over **50** years



Box 615 • Salina, Kansas 67402-0615

Telephone (785) 827-4491 • Fax (785) 827-4494

US 1-800-432-8292 • US 1-800-255-2742 • US 1-800-447-0522

E-mail [grain@grainbeltsupply.com](mailto:grain@grainbeltsupply.com) or [engr@grainbeltsupply.com](mailto:engr@grainbeltsupply.com)

Internet [www.grainbeltsupply.com](http://www.grainbeltsupply.com)